

MODEL NO	F1 (N)	F2 (N)	F3 (N)	F4 (N)	Fi (N)	Vn (dm ³)	AÇI (ANGLE) (± 5 °)	AĞIRLIK (WEIGHT) (gr ±%2)	BAR
682 - 4	2500	1800	9000	6000	750	1.28	90°	5590	6
682 - 6	4000	2400	18000	12000	1150	2.5	90°	9944	6
682 - 8	6500	4000	30000	20000	1850	5.13	90°	21269	6

F1 - F2 : BASKI KUVVETİ (EXERTING FORCE), F3 - F4 : TUTMA KAPASİTESİ (HOLDING CAPACITY), Fi : UYGULAMA KUVVETİ (APPLIED FORCE)

Vn , 6 BAR BASINÇTA ÇİFT HAREKET İÇİN HAVA TÜKETİM MİKTARIDIR (Vn , AIR CONSUMPTION PER DOUBLE STROKE IN dm³ AT 6 BAR)



Ayak Tipi: Yatay Tabanlı

Body Mounting Base: Horizontal

Pistonlar çift etkili, manyetik ve yastıklıdır.
 Pneumatic cylinders are double acting, magnetic and cushioning.



682-M
Sayfa/Page: 93



6031
Sayfa/Page: 122

MODEL NO	A	B	B2	C	D	E2	E3	F	G	H	H1	H2	J	K	L	M	N	X1	X2	P	R	PİSTON Ø	PİSTON STROK
682 - 4	77	90	15	75	27	10	47	70	65,5	130,5	240	455	35	M12X1,25	182	6,2	11	18	64	Ø 16	G1/4	40	80
682 - 6	93	105	20	85	26	11	54	83	71	158	287	535	40	M16X1,50	219	8,2	12,5	18	69	Ø 20	G1/4	50	100
682 - 8	125	145	30	115	40	15	67	115	94	212	333	669	60	M16X1,50	288	12,2	16,5	18	92	Ø 20	G3/8	63	125

MODEL NO	F1 (N)	F2 (N)	F3 (N)	F4 (N)	Fi (N)	Vn (dm ³)	AÇI (ANGLE) (± 5 °)	AĞIRLIK (WEIGHT) (gr ±%2)	BAR
682-4-M	2500	1800	9000	6000	750	1.28	90°	3100	6
682-6-M	4000	2400	18000	12000	1150	2.5	90°	4900	6
682-8-M	6500	4000	30000	20000	1850	5.13	90°	11600	6

F1 - F2 : BASKI KUVVETİ (EXERTING FORCE), F3 - F4 : TUTMA KAPASİTESİ (HOLDING CAPACITY), Fi : UYGULAMA KUVVETİ (APPLIED FORCE)

Vn , 6 BAR BASINÇTA ÇİFT HAREKET İÇİN HAVA TÜKETİM MİKTARIDIR (Vn , AIR CONSUMPTION PER DOUBLE STROKE IN dm³ AT 6 BAR)

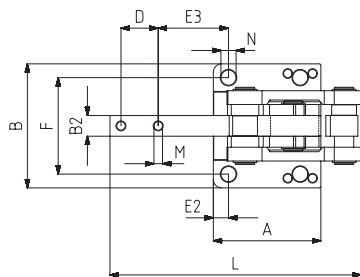
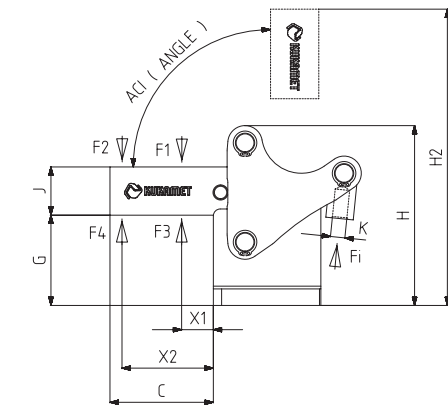

Ayak Tipi: Yatay Tabanlı

Body Mounting Base: Horizontal



681
Sayfa/Page: 92



252
Sayfa/Page: 42



682
Sayfa/Page: 93

MODEL NO	A	B	B2	C	D	E2	E3	F	G	H	H2	J	K	L	M	N	X1	X2	P	R	PİSTON Ø	PİSTON STROK
682-4-M	77	90	15	75	27	10	47	70	65,5	131	216	35	M12X1,25	182	6,2	11	18	64	Ø 16	G1/4	40	80
682-6-M	93	105	20	85	26	11	54	83	71	158	249	40	M16X1,50	219	8,2	12,5	18	69	Ø 20	G1/4	50	100
682-8-M	125	145	30	115	40	15	67	115	94	212	336	60	M16X1,50	288	12,2	16,5	18	92	Ø 20	G3/8	63	125