

621

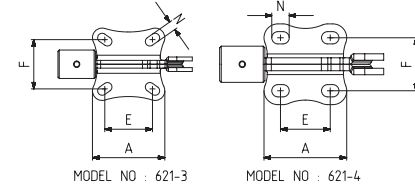

MODEL NO	F1 (N)	F3 (N)	Fi (N)	Vn (dm <sup>3</sup> )	STROK	AĞIRLIK (WEIGHT) (gr ±%2)	BAR
621 - 3 (Ø 12)	1500	2960	300	0.25	23	1140	6
621 - 3 (Ø 14)	2500	3200	500	0.51	23	1310	6
621 - 4 (Ø 16)	4500	6650	750	1.04	33	2230	6
621 - 4 (Ø 18)	4500	7200	750	1.04	33	2260	6
621 - 5 (Ø 20)	7500	15000	1100	2	42	3860	6

F1 : BASKI KUVVETİ ( EXERTING FORCE ) , F3 : TUTMA KAPASİTESİ ( HOLDING CAPACITY ) , Fi : UYGULAMA KUVVETİ ( APPLIED FORCE )  
 Vn , 6 BAR BASINÇTA ÇİFT HAREKET İÇİN HAVA TÜKETİM MİKTARIDIR ( Vn , AIR CONSUMPTION PER DOUBLE STROKE IN dm<sup>3</sup> AT 6 BAR )

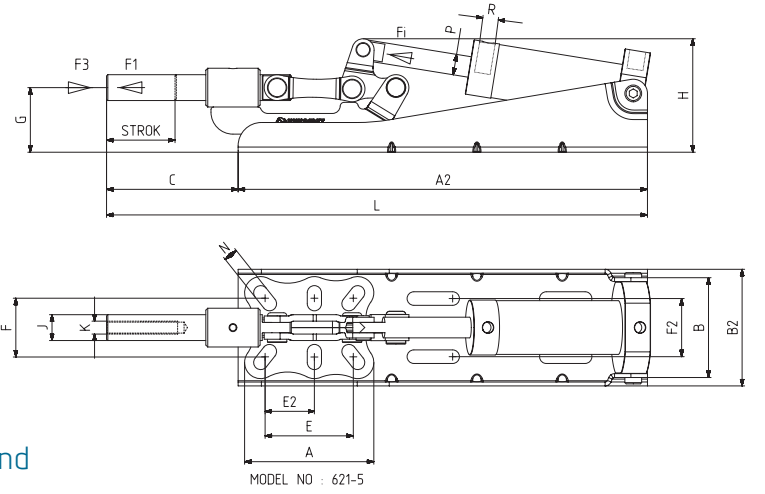

### Ayak Tipi: Yatay Tabanlı, Kaynaklı, Arka Bağlantılı

Body Mounting Base: Horizontal With Welding, Tied Behind



**Pistonlar çift etkili, manyetik ve yastıklıdır.**  
 Pneumatic cylinders are double acting, magnetic and cushioning.

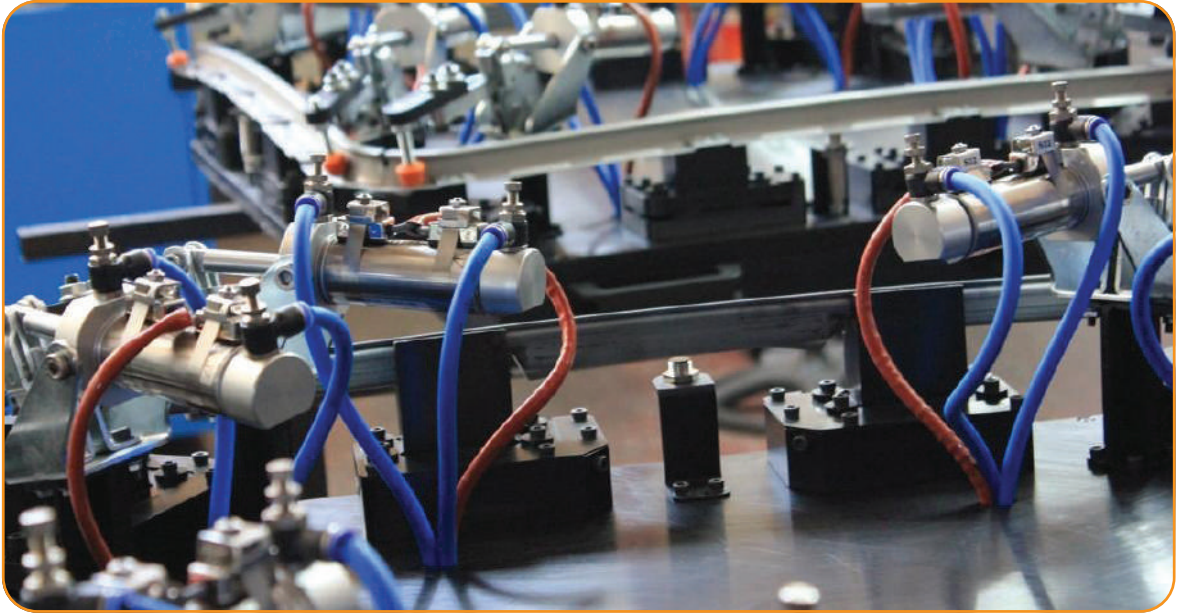

MODEL NO	A	A2	B	B2	C	E	E2	F	F2	G	H	J	K	L	N	P	R	PİSTON Ø
621 - 3 (Ø 12)	56	226	51	68	70	37	-	38	35	35	65	12	M8	296	7 x 12	Ø 10	G1/8	25
621 - 3 (Ø 14)	56	243	58	68	70	37	-	38	35	35	71.5	14	M8	314	7 x 12	Ø 12	G1/8	32
621 - 4 (Ø 16)	64	289	77	78	84	38,5	-	41	41	43	89	16	M10	375	9,5x13,5	Ø 16	G1/8	40
621 - 4 (Ø 18)	64	289	77	78	84	38,5	-	41	41	43	89	18	M10	375	9,5x13,5	Ø 16	G1/8	40
621 - 5 (Ø 20)	100	355	79	92	101	68	38	45,5	45	51	105	20	M12	460	11 x 22	Ø 20	G1/8	50