

MODEL NO	F1 (N)	F2 (N)	F3 (N)	F4 (N)	Fi (N)	Vn (dm ³)	AÇI (ANGLE) (± 5°)	AĞIRLIK (WEIGHT) (gr ±%2)	BAR
612 - 2	1200	700	1400	925	300	0,25	95°	535	6
612 - 3	2000	1400	2500	1560	500	0,51	95°	860	6

F1 - F2 : BASKI KUVVETİ (EXERTING FORCE) , F3 - F4 : TUTMA KAPASİTESİ (HOLDING CAPACITY) , Fi : UYGULAMA KUVVETİ (APPLIED FORCE)

Vn , 6 BAR BASINÇTA ÇİFT HAREKET İÇİN HAVA TÜKETİM MİKTARIDIR (Vn , AIR CONSUMPTION PER DOUBLE STROKE IN dm³ AT 6 BAR)

612

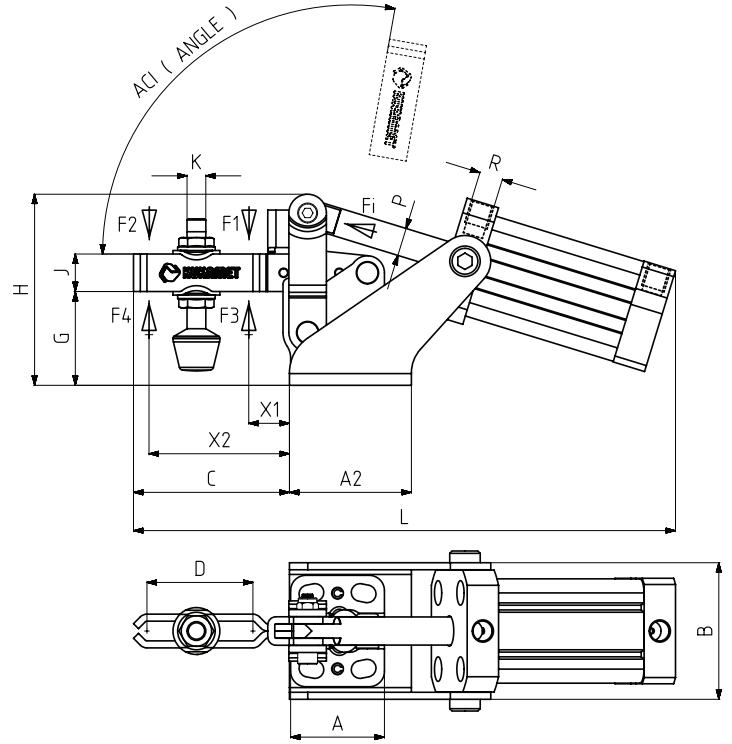
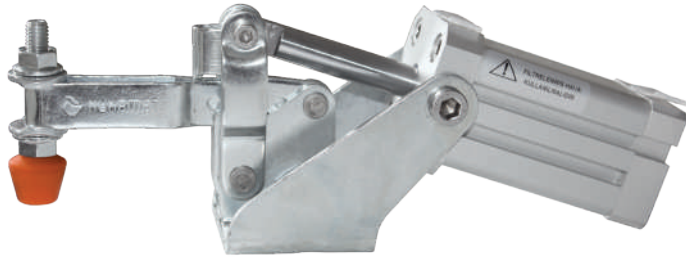

Ayak Tipi: Yatay Tabanlı, Ön Bağlantılı
 Body Mounting Base: Horizontal, Tied Front

Sensör Kanallı - Kare Pistonlu
 With Square Piston and Sensor Slot

Pistonlar çift etkili, manyetik ve yastıklıdır.
 Pneumatic cylinders are double acting, magnetic and cushioning

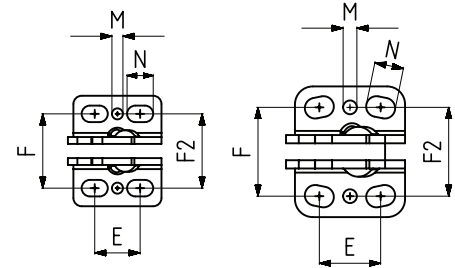

MODEL NO : 612-2

MODEL NO : 612-3



MODEL NO	A	A2	B	C	D	E	F	F2	G	H	J	K	L	M	N	X1	X2	P	R	PİSTON Ø
612 - 2	32	42	51	60	42	16,5	27	27	29	61	13	M6	203	Ø4	6 x 9,5	18	48	Ø 10	G1/8	25
612 - 3	40	52	58	66,5	42	22,5	32,3	32,3	40	81,5	16	M 8	231	Ø5	7,5 x 10,5	25	52	Ø 12	G1/8	32