

MODEL NO	F1 (N)	F2 (N)	F3 (N)	F4 (N)	Fi (N)	Vn (dm ³)	AÇI (ANGLE) (± 5 °)	AĞIRLIK (WEIGHT) (gr ±%2)	BAR
611 - 1 - Q16	600	400	1000	680	120	0,09	95°	275	6
611 - 1 - Q20	750	500	1000	680	190	0,14	95°	360	6
611 - 2	1200	700	1400	925	300	0,25	95°	535	6
611 - 3	2000	1400	2500	1560	500	0,51	95°	860	6
611 - 4	3000	2000	3300	2200	750	1,04	95°	1690	6
611 - 5	4500	2500	5000	3000	1100	2	95°	3090	6

F1 - F2 : BASKI KUVVETİ (EXERTING FORCE), F3 - F4 : TUTMA KAPASİTESİ (HOLDING CAPACITY), Fi : UYGULAMA KUVVETİ (APPLIED FORCE)

Vn , 6 BAR BASINÇTA ÇİFT HAREKET İÇİN HAVA TÜKETİM MİKTARIDIR (Vn , AIR CONSUMPTION PER DOUBLE STROKE IN dm³ AT 6 BAR)

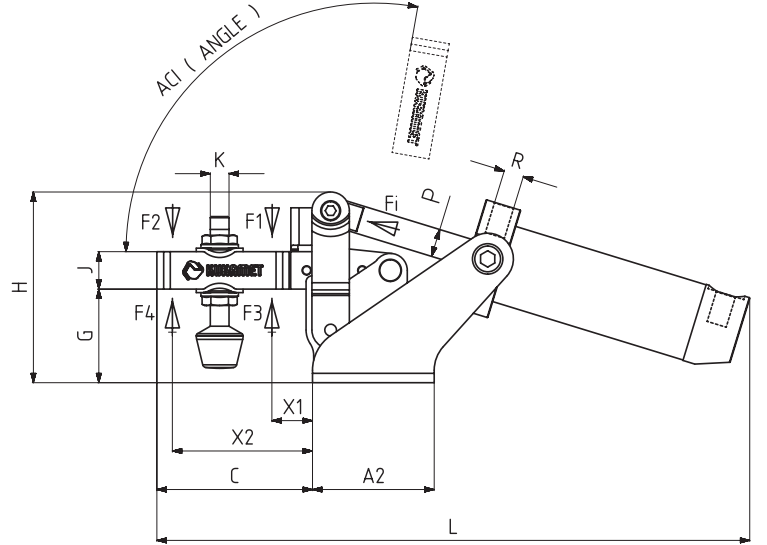
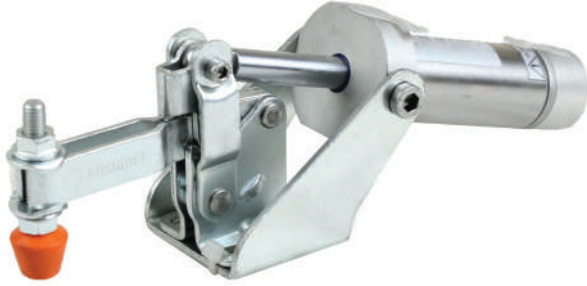

Ayak Tipi: Yatay Tabanlı, Ön Bağlantılı

Body Mounting Base: Horizontal, Tied front

Pistonlar çift etkili, manyetik ve yastıklıdır.
 Pneumatic cylinders are double acting, magnetic and cushioning.

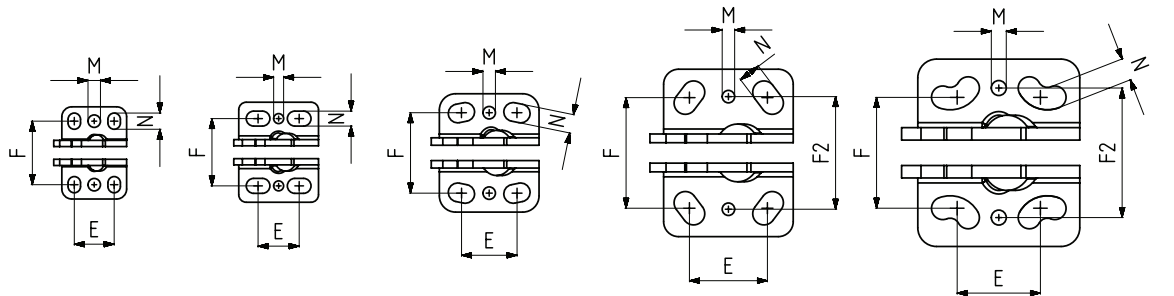
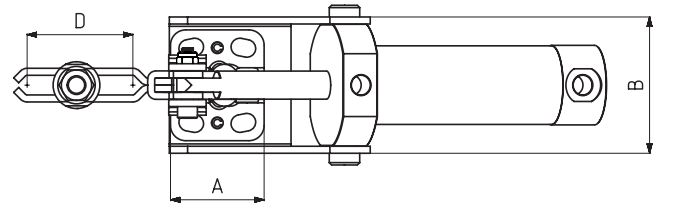

MODEL NO : 611-1

MODEL NO : 611-2

MODEL NO : 611-3

MODEL NO : 611-4

MODEL NO : 611-5



612

Sayfa/Page: 80



211

Sayfa/Page: 17

MODEL NO	A	A2	B	C	D	E	F	F2	G	H	J	K	L	M	N	X1	X2	P	R	PİSTON Ø
611 - 1 - Q16	26	34	44	42	26	16	25,5	25,5	25	52	10	M5	185	Ø5	5 x 6,5	16	32	Ø 6	M5	16
611 - 1 - Q20	26	34	44	44	26	16	25,5	25,5	25	52	10	M5	192	Ø5	5 x 6,5	16	32	Ø 8	G1/8	20
611 - 2	32	42	51	60	42	16,5	27	27	29	61	13	M6	225	Ø4	6 x 9,5	18	48	Ø 10	G1/8	25
611 - 3	40	52	58	66,5	42	22,5	32,3	32,3	40	81,5	16	M 8	253,5	Ø5	7,5 x 10,5	25	52	Ø 12	G1/8	32
611 - 4	52	95	77	98,5	67	31,5	44,5	45,2	50	104	20	M10	323	Ø5	9 x 14,5	32	80	Ø 16	G1/8	40
611 - 5	65	134	92	124	88	33,5	44,5	52	62	128	25	M12	399	Ø6	9 x 19,5	36	101	Ø 20	G1/8	50