

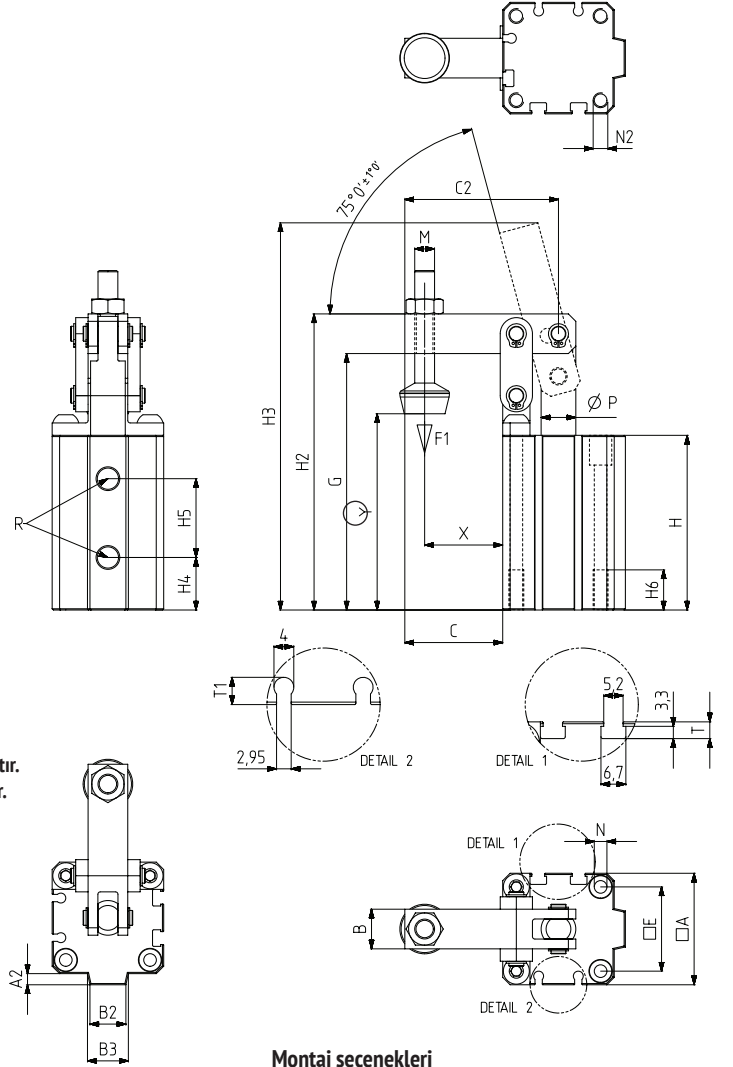



MODEL NO	F1 (N)	Vn (dm ³)	BASKI VİDASI (SQUEEZE SCREW)	AĞIRLIK (WEIGHT) (gr ±%)	BAR
6017 - 25	100	0,13	M6 x 40	360	6
6017 - 32	300	0,19	M8 x 50	530	6
6017 - 40	500	0,38	M8 x 50	720	6
6017 - 50	700	0,79	M10 x 70	1110	6

F1 : BASKI KUVVETİ (EXERTING FORCE)

Vn, 6 BAR BASINÇTA ÇİFT HAREKET İÇİN HAVA TÜKETİM MİKTARIDIR (Vn, AIR CONSUMPTION PER DOUBLE STROKE IN dm³ AT 6 BAR)



PNÖMATİK BAĞLANTI ELEMANI - LINK KARE GÖVDE

- Silindir çift etkili ve manyettiktir.
- Gövde mukavemetli alüminyumdan üretilmiştir. Korozyon direnci için eloksal kaplama yapılmıştır.
- Piston mili yüksek aşınma ve korozyon direnci için sert krom kaplama yapılmış ve parlatılmıştır.
- Mekanizma parçaları çelik malzemeden üretilmiş ve korozyon direnci için fosfat kaplama yapılmıştır.
- Piston konumunu izlemek için, gövde üzerinde "T" tip ve "C" tip sensörlere uygun kanallar mevcuttur.

Aksesuarlar : (fiyata dahil değildir)

1-) Baskı ucu (911, 912, 913, 914, 915, 916)

PNEUMATIC TOGGLE CLAMP - LINK SQUARE BODY

- Cylinder is double acting and magnetic.
- The body is made of strength aluminum. Anodised for Corrosion resistance.
- The piston rod is hard chrome plated and shapely polished for to high wear resistance and corrosion resistance.
- Parts of the mechanism are made of steel and phosphate coated for corrosion resistance.
- There are slots on the body, according to T type and C type sensors, for monitoring the position of piston.

Accessories : (not included in the price)

1-) Squeeze part (911,912,913,914,915,916)



6011

Sayfa/Page: 109



6012

Sayfa/Page: 110



6031

Sayfa/Page: 122

Montaj seçenekleri

Mounting options

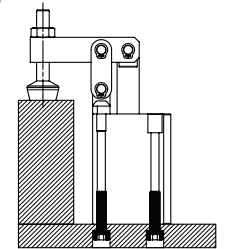
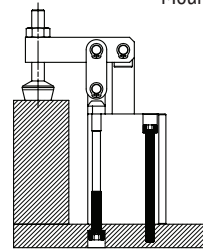

1- Gövde üzerindeki deliklerden imbus civata (DIN 912) ile yukarıdan montaj.

1- Mounting from above with socket bolt (DIN 912) through to holes on the body.

2- Gövde alt yüzündeki, klavuz çekilmiş delikler kullanılarak montaj.

2- Mounting through to tapped holes on the lower surface of body.

MODEL NO	A	A2	B	B2	B3	C	C2	E	G	H	H2	H3	H4	H5	H6	M	N	N2	P	R	T	T1	X	Y Min	Y Max	PİSTON Ø
6017 - 25	40	4	14	10,5	12,5	34	54	29	80,5	58	94,5	124,5	15,6	30,9	15	M6	Ø5,1	M6	12	M5	5	5,5	27	54	70	25
6017 - 32	45	4,5	16	14,5	16,5	37,5	60	34	96	66,5	112	145	21,2	33,2	17	M8	Ø5,1	M6	14	G1/8	4,5	5,5	29,5	61	83	32
6017 - 40	55	5	16	19,5	24	32,5	60	40	104	72	119	148	21,2	38,8	17	M8	Ø5,5	M8	14	G1/8	6,5	7	24,5	69	91	40
6017 - 50	64	6	20	20	23	38	70	50	115	79	135	165	20,2	46,6	17	M10	Ø6,5	M8	20	G1/8	6	6,5	28	63	98	50