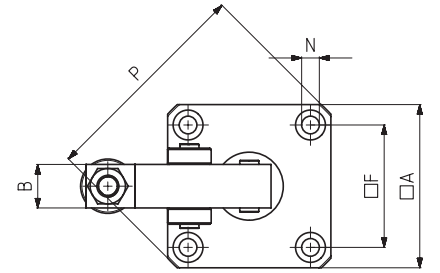
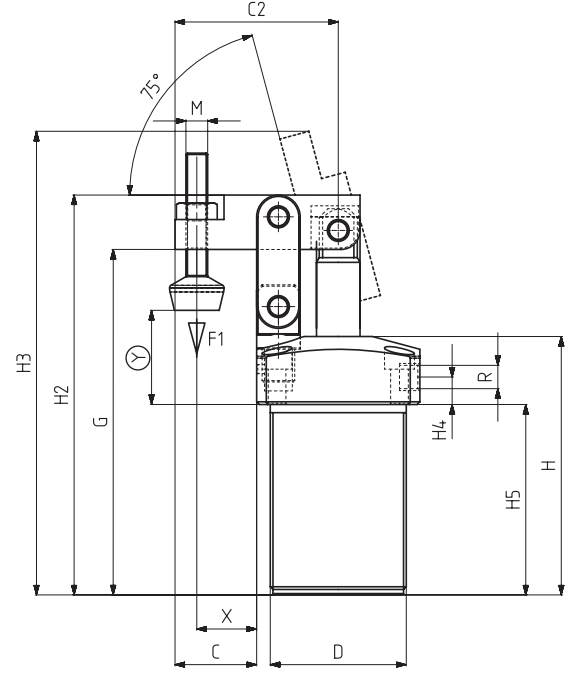

**6015**

MODEL NO	F1 (N)	Vn (dm <sup>3</sup> )	BASKI VİDASI (SQUEEZE SCREW)	AĞIRLIK (WEIGHT) (gr ±%)	BAR
6015 - 25	200	0,13	M6 x 40	600	6
6015 - 32	300	0,25	M8 x 50	950	6
6015 - 40	500	0,46	M8 x 50	1100	6
6015 - 50	700	0,79	M12 x 80	1707	6

F1 : BASKI KUVVETİ ( EXERTING FORCE )

 Vn, 6 BAR BASINÇTA ÇİFT HAREKET İÇİN HAVA TÜKETİM MİKTARIDIR ( Vn, AIR CONSUMPTION PER DOUBLE STROKE IN dm<sup>3</sup> AT 6 BAR )

**Not: Filtrelenmiş ve yağlanmış hava kullanılmalıdır.**  
 Note: Operate only with filtered and lubricated air.

**PNÖMATİK BAĞLANTI ELEMANI - LİNK FLANŞ BAĞLANTILI GÖVDE**

- Silindir çift etkilidir.
- Gövde mukavemetli alüminyumdan üretilmiştir. Korozyon direnci için eloksal kaplama yapılmıştır.
- Piston mili yüksek aşınma ve korozyon direnci için sert krom kaplama yapılmış ve parlatılmıştır.
- Mekanizma parçaları çelik malzemeden üretilmiş ve korozyon direnci için fosfat kaplama yapılmıştır.

Aksesuarlar : ( fiyata dahil değildir )

- 1-) Bağlantı somunu ( 6010-3 )
- 2-) Bağlantı flanşı ( 6010-4 )
- 3-) Baskı ucu ( 911, 912, 913, 914, 915, 916 )

**PNEUMATIC TOGGLE CLAMP - LINK-FLANGE MOUNTING BODY**

- Cylinder is double acting.
- The body is made of strength aluminum.
- Anodised for Corrosion resistance.
- The piston rod is hard chrome plated and shapely polished for to high wear resistance and corrosion resistance.
- Parts of the mechanism are made of steel and phosphate coated for corrosion resistance.

Accessories : ( not included in the price )

- 1-) Connection nut ( 6010-3 )
- 2-) Connection flange ( 6010-4 )
- 3-) Squeeze part ( 911, 912, 913, 914, 915, 916 )



6013



6014



6016



6031

Sayfa/Page: 111 Sayfa/Page: 112 Sayfa/Page: 114 Sayfa/Page: 122

**Montaj seçenekleri**

Mounting options

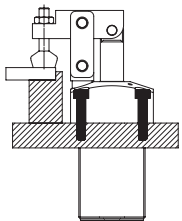
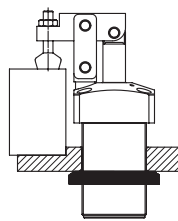
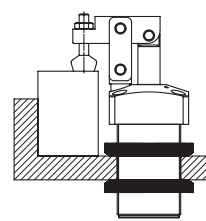
 1- Flanş sayesinde imbus civata ( DIN 912 ) ile yukarıdan montaj.  
 1- Mounting from above with imbus bolt through the flange. (DIN 912)

 2- Gövdeyi klavuz çekilmiş bir delik içine vidalama ve bağlantı somunu ile sıkarak montaj ( 6010-3 )  
 2- By screwing the body into a tapped hole and mounting with connection nut ( 6010-3 )

 3- Gövde düz bir delik içine yerleştirilerek, bağlantı somunları ile aşağıdan ve yukarıdan sıkarak montaj ( 6010-3 )  
 3- By inserting the body into a plain hole and mounting with connection nuts, from above and from below ( 6010-3 )

MODEL NO	A	B	C	C2	D	F	G	H	H2	H3	H4	H5	M	ØN	P	R	X	Y Min	Y Max	PİSTON Ø
6015 - 25	50	16	25	50	M 40 x 1,5	37	114	87	134	148	12	62	M6	5,5	66	M5	16	20	39	25
6015 - 32	60	16	30	60	M 50 x 1,5	45	132	100	152	172	10	73	M8	6,5	80	G1/8	22	19	46	32
6015 - 40	65	16	35,5	68	M 55 x 1,5	50	132	100	156	181	10	73	M8	6,5	85	G1/8	23,5	22	47	40
6015 - 50	75	20	41,5	79	M 65 x 1,5	58	146	106	176	202	11	79	M12	8,5	100	G1/8	26	2	45	50