

691



MODEL NO	F1 (N)	F2 (N)	F3 (N)	F4 (N)	Fi (N)	Vn (dm ³)	AĞIRLIK (WEIGHT) (gr ±%2)	BAR
691-1	1000	1000	1000	1000	300	0,25	641	6
691-2	2000	2000	2000	2000	500	0,51	1173	6
691-3	3000	3000	3000	3000	750	1,04	2440	6

F1 - F2 : BASKI KUVVETİ (EXERTING FORCE), F3 - F4 : TUTMA KAPASİTESİ (HOLDING CAPACITY), Fi : UYGULAMA KUVVETİ (APPLIED FORCE)

Vn , 6 BAR BASINÇTA ÇİFT HAREKET İÇİN HAVA TÜKETİM MİKTARIDIR (Vn , AIR CONSUMPTION PER DOUBLE STROKE IN dm³ AT 6 BAR)

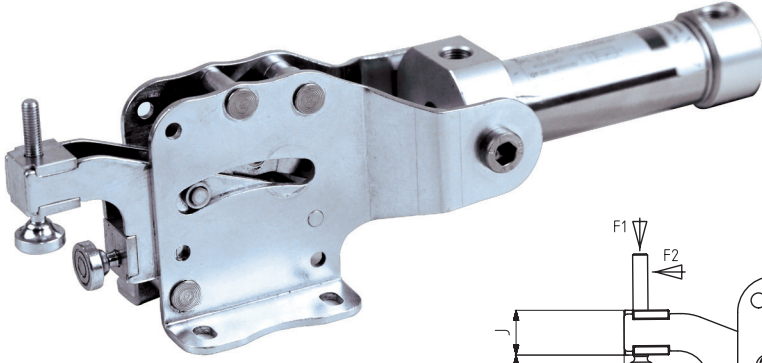

Ayak Tipi: Yatay Tabanlı
Body Mounting Base: Horizontal

Pistonlar çift etkili, manyetik ve yastıklıdır.
Pneumatic cylinders are double acting, magnetic and cushioning

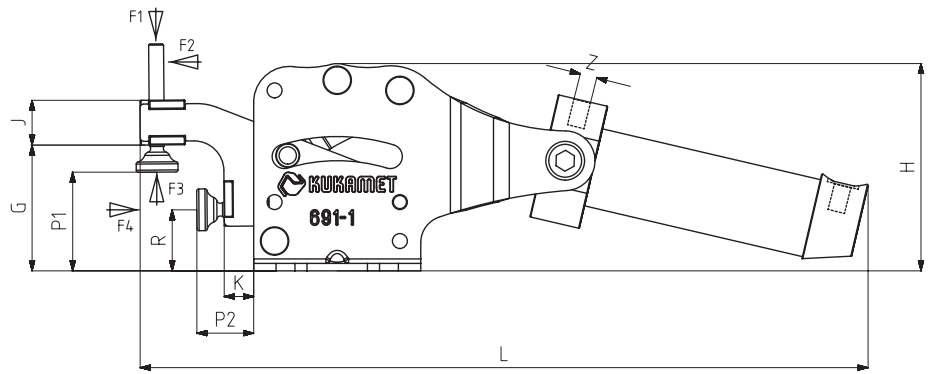

611 Sayfa/Page: 70

711 Sayfa/Page: 88

252 Sayfa/Page: 38

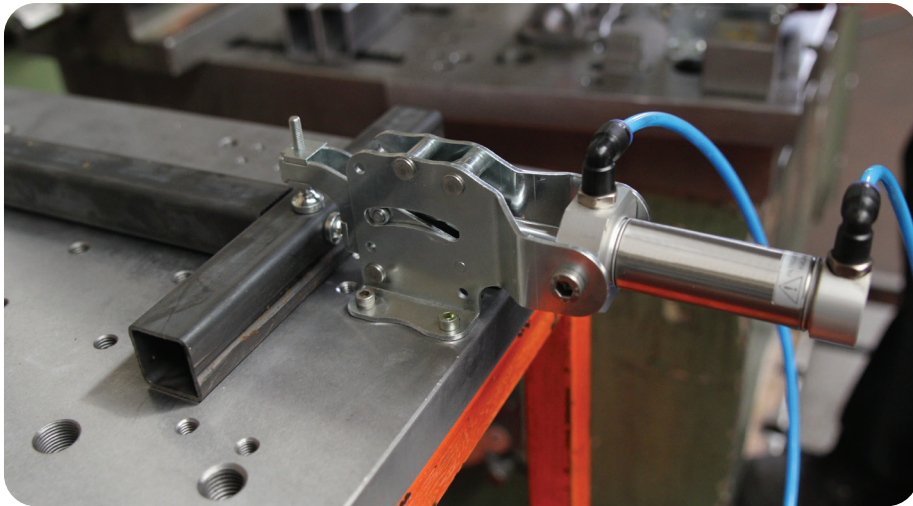
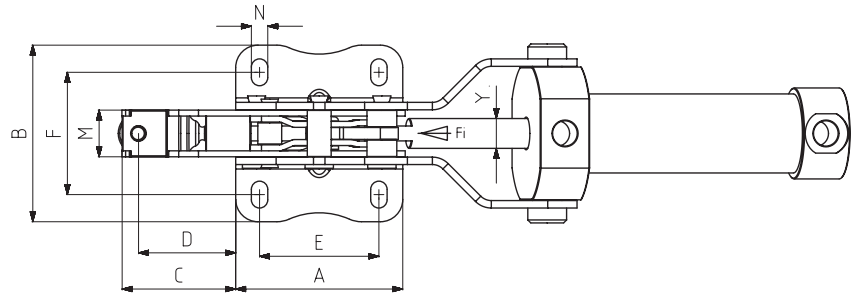

MODEL NO	A	B	C	D	E	F	G	H	J	K	L	M	N	P1 Min.	P1 Max.	P2 Min.	P2 Max.	R	Y	Z	PİSTON Ø
691-1	56	59,5	38	32,5	40	41	42	70	15	10	244	16	5,5 x 9	15	33	19	37	20,5	10	G1/8	25
691-2	75	79,5	48	41	50	56	52	88	20	12	291	20	6,5 x 13	24	41	22	39	24,5	12	G1/8	32
691-3	90	101,5	58	50	50	71	62	105	25	15	356,5	30	8,5 x 18,5	23	49	28	54	29	16	G1/8	40