

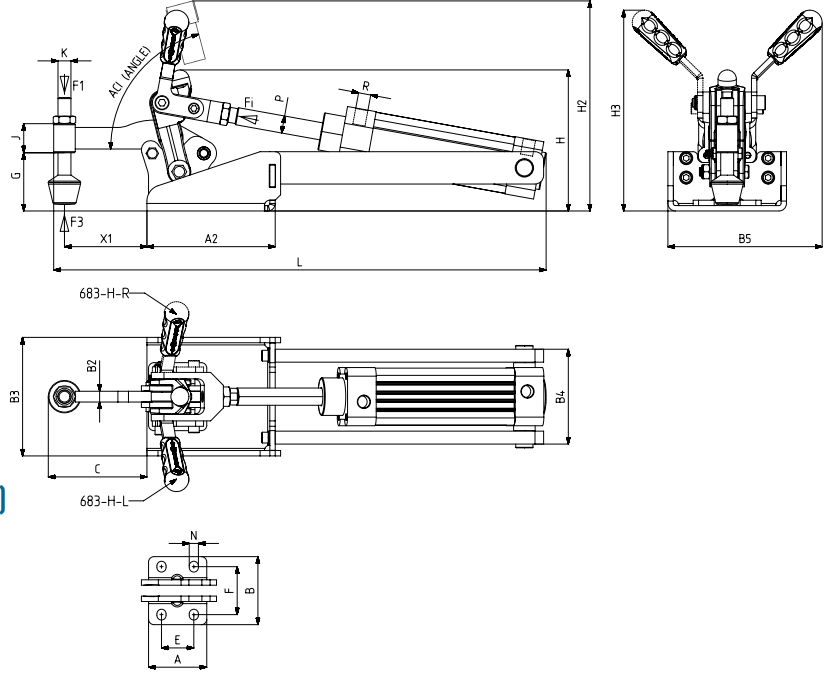
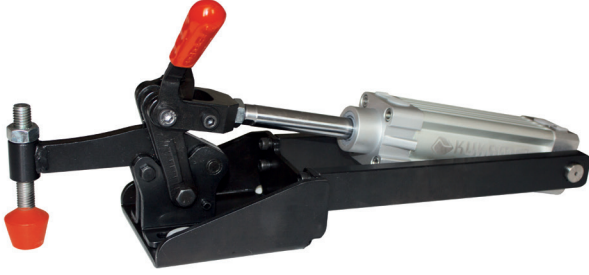

683-H

MODEL NO (KOLLU) / WITH HANDLE	F1 (N)	F3 (N)	Fİ (N)	Vn (dm ³)	AÇI (ANGLE) (± 5 °)	AĞIRLIK (WEIGHT) (gr ±%2)	BAR
683 - 4-H-L / ..H-R	1600	5600	750	1,28	70°	4980	6
683 - 6-H-L / ..H-R	2000	11000	1150	2,5	70°	8130	6

F1 : BASKI KUVVETİ (EXERTING FORCE) , F3 : TUTMA KAPASİTESİ (HOLDING CAPACITY) , Fİ : UYGULAMA KUVVETİ (APPLIED FORCE)

Vn , 6 BAR BASINÇTA ÇİFT HAREKET İÇİN HAVA TÜKETİM MİKTARIDIR (Vn , AIR CONSUMPTION PER DOUBLE STROKE IN dm³ AT 6 BAR)



Ayak Tipi: Yatay Tabanlı, Kollu (Modüler Pistonlu)
 Body Mounting Base: Horizontal and with handle
 (Modular with piston)



6011

Sayfa/Page: 101



683

Sayfa/Page: 85

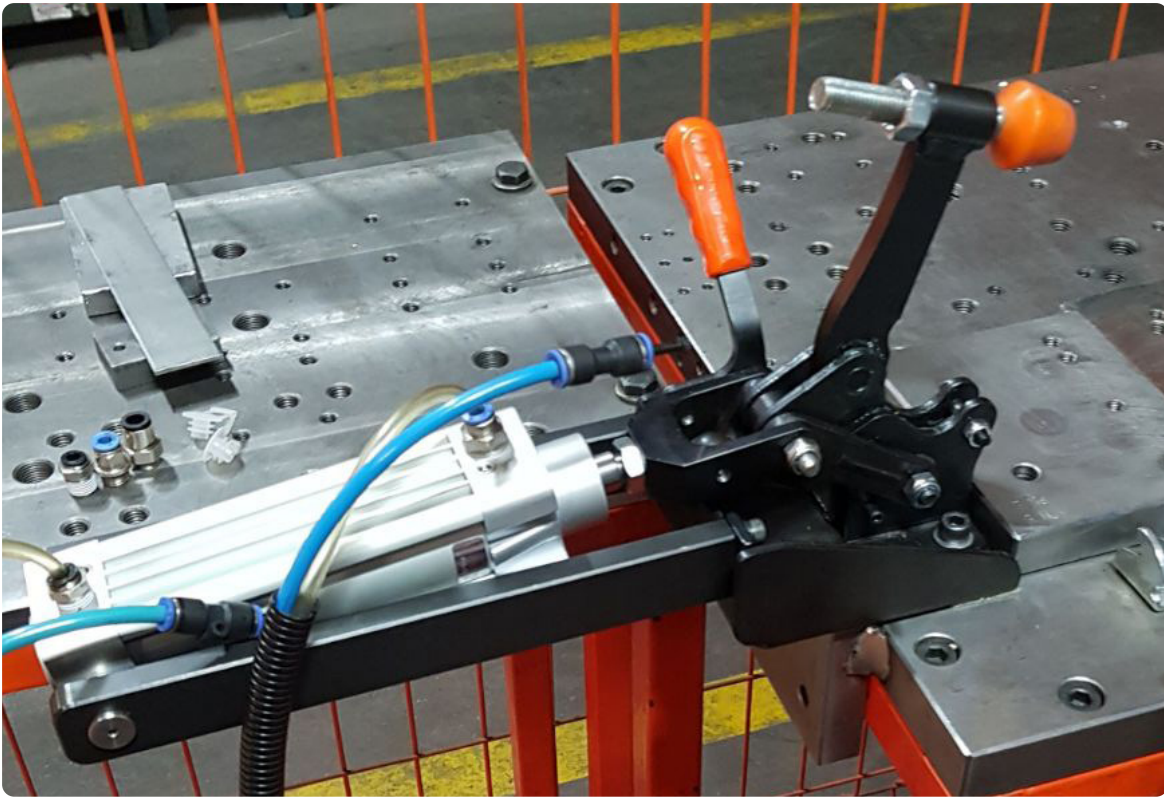

Pistonlar çift etkili, manyetik ve yastıklıdır.

Pneumatic cylinders are double acting, magnetic and cushioning.

MODEL NO (KOLLU) / WITH HANDLE	A	A2	B	B2	B3	B4	B5	C	E	F	G	H	H2	H3	J	K	L	N	X1	P	R	PİSTON Ø	PİSTON STROK
683 - 4-H-L / ..H-R	54	119	63	10	100	88	138	91,5	30	44,5	54	131	195	186	27	M12	457	8,5 x 10	76,5	Ø 16	G1/4	40	80
683 - 6-H-L / ..H-R	70	151	74	12	112	100	188,5	112	45	52	73	164	245	256	32	M12	549	10,5 x 11,5	97	Ø 20	G1/4	50	100