

681



MODEL NO	F1 (N)	F2 (N)	F3 (N)	F4 (N)	Fİ (N)	Vn (dm <sup>3</sup> )	AÇI (ANGLE) (± 5 °)	AĞIRLIK (WEIGHT) (gr ±%)	BAR
681 - 4	2500	1800	9000	6000	750	1.28	90°	5565	6
681 - 6	4000	2400	18000	12000	1150	2.5	90°	9660	6
681 - 8	6500	4000	30000	20000	1850	5.13	90°	20475	6

F1 - F2 : BASKI KUVVETİ ( EXERTING FORCE ) , F3 - F4 : TUTMA KAPASİTESİ ( HOLDING CAPACITY ) , Fİ : UYGULAMA KUVVETİ ( APPLIED FORCE )

Vn , 6 BAR BASINÇTA ÇİFT HAREKET İÇİN HAVA TÜKETİM MİKTARIDIR ( Vn , AIR CONSUMPTION PER DOUBLE STROKE IN dm<sup>3</sup> AT 6 BAR )

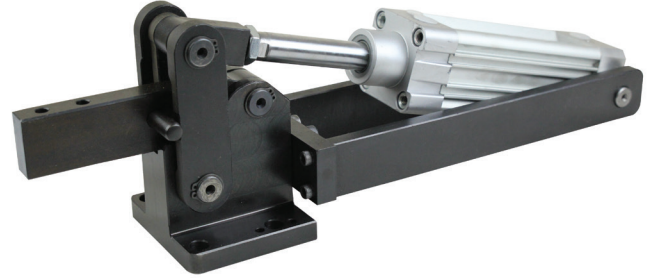

**Ayak Tipi: Çatay Tabanlı**  
Body Mounting Base: Horizontal

**Pistonlar çift etkili, manyetik ve yastıklıdır.**  
Pneumatic cylinders are double acting, magnetic and cushioning



681-M  
Sayfa/Page: 83



682  
Sayfa/Page: 84



6031  
Sayfa/Page: 114

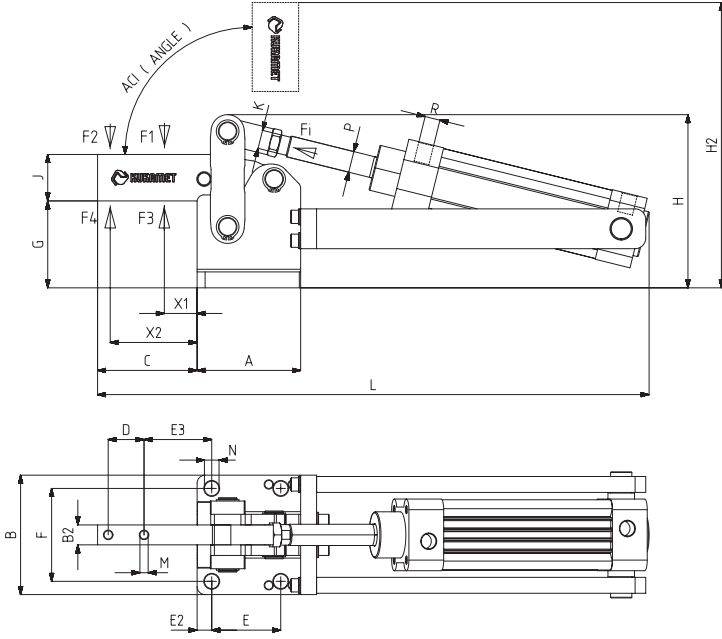

MODEL NO	A	B	B2	C	D	E	E2	E3	F	G	H	H2	J	K	L	M	N	X1	X2	P	R	PİSTON Ø	PİSTON STROK
681 - 4	77	90	15	75	27	52	10	47	70	65,5	131	216	35	M12X1,25	416	6,2	11	18	64	Ø 16	G1/4	40	80
681 - 6	93	105	20	85	26	55	11	54	83	71	158	249	40	M16X1,50	483	8,2	12,5	18	69	Ø 20	G1/4	50	100
681 - 8	125	145	30	115	40	80	15	67	115	94	212	336	60	M16X1,50	594	12,2	16,5	18	92	Ø 20	G3/8	63	125

681-M

MODEL NO	F1 (N)	F2 (N)	F3 (N)	F4 (N)	Fİ (N)	Vn (dm <sup>3</sup> )	AÇI (ANGLE) (± 5 °)	AĞIRLIK (WEIGHT) (gr ±%)	BAR
681-4-M	2500	1800	9000	6000	750	1,28	90°	2800	6
681-6-M	4000	2400	18000	12000	1150	2,5	90°	4600	6
681-8-M	6500	4000	30000	20000	1850	5,13	90°	11300	6

F1 - F2 : BASKI KUVVETİ ( EXERTING FORCE ) , F3 - F4 : TUTMA KAPASİTESİ ( HOLDING CAPACITY ) , Fİ : UYGULAMA KUVVETİ ( APPLIED FORCE )

Vn , 6 BAR BASINÇTA ÇİFT HAREKET İÇİN HAVA TÜKETİM MİKTARIDIR ( Vn , AIR CONSUMPTION PER DOUBLE STROKE IN dm<sup>3</sup> AT 6 BAR )

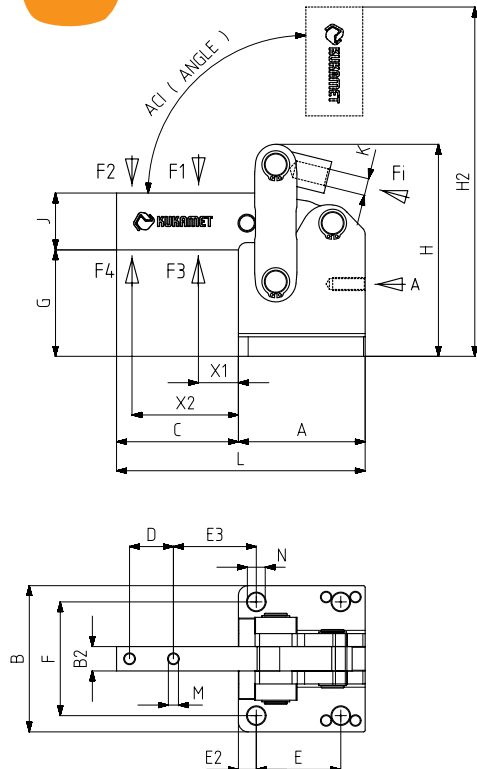

VIEW A

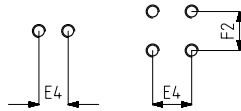

**Ayak Tipi: Çatay Tabanlı**  
Body Mounting Base: Horizontal



681  
Sayfa/Page: 83



252  
Sayfa/Page: 38

MODEL NO	A	B	B2	C	D	E	E2	E3	E4	F	F2	G	H	H2	J	K	L	M	N	X1	X2	P	R	PİSTON Ø	PİSTON STROK
681-4-M	77	90	15	75	27	52	10	47	18	70	-	65,5	131	215,5	35	M12X1,25	152	6,2	11	18	64	16	G1/4	40	80
681-6-M	93	105	20	85	26	55	11	54	24	83	24	71	158	249	40	M16X1,50	178	8,2	12,5	18	69	20	G1/4	50	100
681-8-M	125	145	30	115	40	80	15	67	34	115	40	94	212	336	60	M16X1,50	240	12,2	16,5	18	92	20	G3/8	63	125