

6031

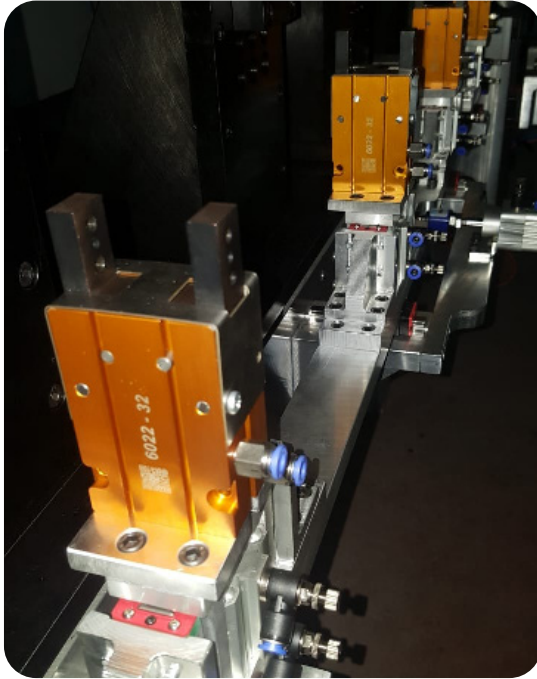

MODEL NO	SIKMA KUVVETİ (CLAMPING MOMENT) (at 5 bar) (Nm) F1	TUTMA KUVVETİ (HOLDING MOMENT) (Nm) F3	AĞIRLIK (WEIGHT) (gr ±%2)
6031 - 50	160	800	3500

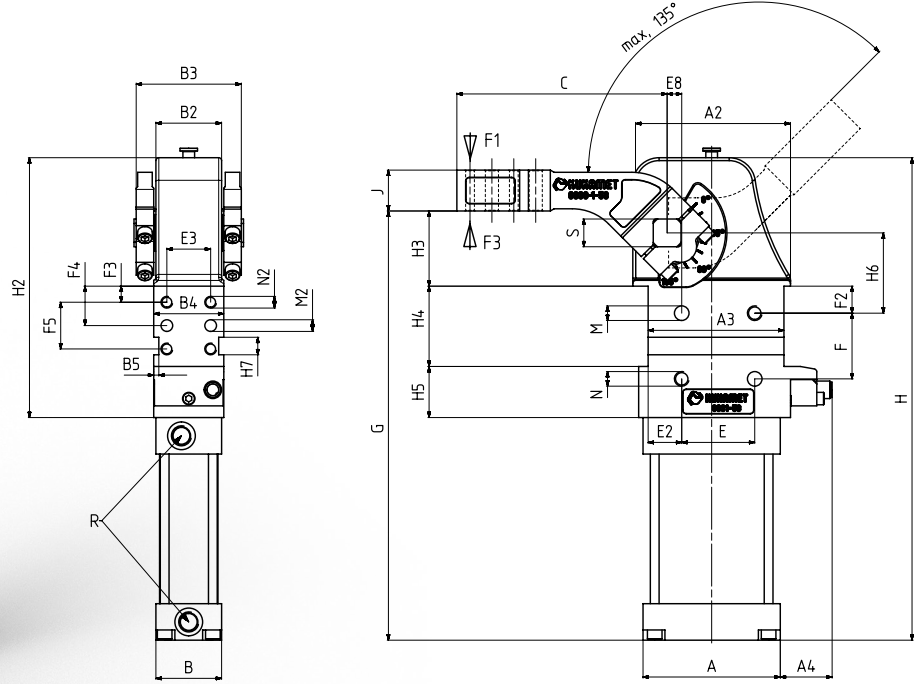

ORDERING EXAMPLE :

- 6031-50 (CLAMP ARM CENTER)
- 6031-50-R (CLAMP ARM RIGHT)
- 6031-50-L (CLAMP ARM LEFT)

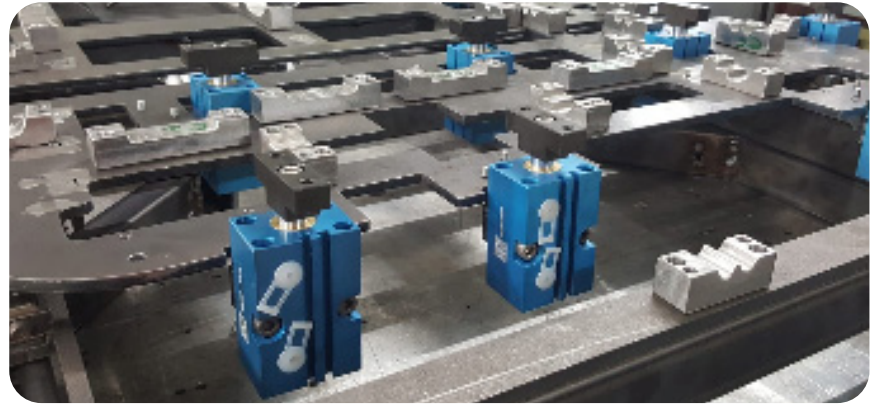
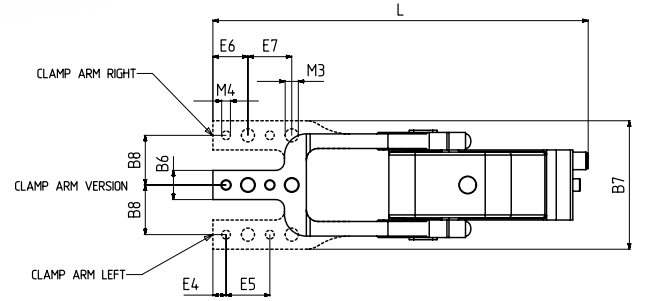

MODEL NO	A	A2	A3	A4	B	B2	B3	B4	B5	B6	B7	B8	C	E	E2	E3	E4	E5	E6	E7	E8
6031 - 50	94	108	93	35,5	45	45	72	48	3,5	20	88	34	144	50	23	30	9	30	24	30	10

MODEL NO	F	F2	F3	F4	F5	G	H	H2	H3	H4	H5	H6	H7	J	L	M (H7)	N	M2 (H7)	N2	M3	M4 (H7)	R	S
6031 - 50	45	18,5	11	27	32	294	330,5	178	50,5	55	35	55	12	30	257	Ø10	M10	Ø8	M8	9	6	G1/4	19