

**6011**

MODEL NO	F1 (N)	Vn (dm <sup>3</sup> )	STROK	AĞIRLIK (WEIGHT) (gr ±½%)	BAR
6011 - 25R	200	0,1	28	360	6
6011 - 25L	200	0,1	28	360	6
6011 - 32R	300	0,23	26	600	6
6011 - 32L	300	0,23	26	600	6
6011 - 40R	600	0,4	26	780	6
6011 - 40L	600	0,4	26	780	6
6011 - 50R	900	0,96	38	1430	6
6011 - 50L	900	0,96	38	1430	6

F1 : BASKI KUVVETİ (EXERTING FORCE)

 Vn, 6 BAR BASINÇTA ÇİFT HAREKET İÇİN HAVA TÜKETİM MİKTARIDIR (Vn, AIR CONSUMPTION PER DOUBLE STROKE IN dm<sup>3</sup> AT 6 BAR)

**Not: Filtrelenmiş ve yağlanmış hava kullanılmalıdır.**  
 Note: Operate only with filtered and lubricated air.

**DÖNER TİP PNÖMATİK BAĞLANTI ELEMANI - KARE GÖVDE**

- Silindirik çift etkili ve manyetikdir.
- Gövde mukavemetli alüminyumdan üretilmiştir. Korozyon direnci için eloksal kaplama yapılmıştır.
- Piston mili yüksek aşınma ve korozyon direnci için sert krom kaplama yapılmış ve parlatılmıştır.
- Piston mili, koruma adaptörü sayesinde kaynak çapakları ve dış etkenlerden korunmaktadır.
- Piston konumunu izlemek için, gövde üzerinde "T" tip ve "C" tip sensörlere uygun kanallar mevcuttur.

Aksesuarlar : ( fiyata dahil değildir )

- 1-) Piston mili koruma adaptörü ( 6010-5 )
- 2-) Koruma adaptörü için sıkma kolu ( 6010-6 )
- 3-) Baskı ucu ( 911, 912, 913, 914, 915, 916 )
- 4-) Sıkma kolu adaptörü ( 6010-8 )

**PNEUMATIC SWING CLAMP - SQUARE BODY**

- Cylinder is double acting and magnetic.
- The body is made of strength aluminum. Anodised for Corrosion resistance.
- The piston rod is hard chrome plated and shapely polished for to high wear resistance and corrosion resistance.
- Piston rod, protected against welding spatter and external factors through the protection adapter.
- There are slots on the body, according to T type and C type sensors, for monitoring the position of piston.

Accessories : ( not included in the price )

- 1-) Piston rod protection adapter. ( 6010-5 )
- 2-) Squeezing arm for protection adapter ( 6010-6 )
- 3-) Squeeze part ( 911,912,913,914,915,916 )
- 4-) Squeezing Arm Adapter ( 6010-8 )



6012

Sayfa/Page: 102



6017

Sayfa/Page: 107



6031

Sayfa/Page: 114

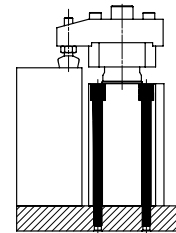
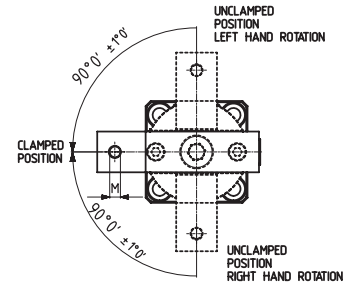
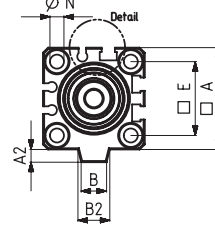
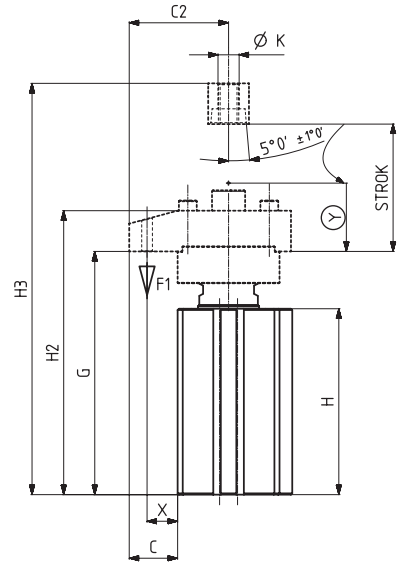
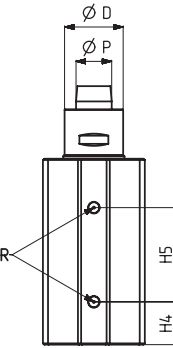
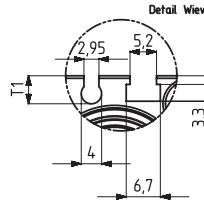
**Montaj seçenekleri**  
 Mounting options

- Gövde üzerindeki deliklerden imbus civata ( DIN 912 ) ile yukarıdan montaj.
- Mounting from above with socket bolt (DIN 912) through to holes on the body.

MODEL NO	A	A2	B	B2	C	C2	D	E	G	H	H2	H3	H4	H5	K	M	N	P	R	T	T1	X	Y	PİSTON Ø
6011 - 25R	40	4	10,5	12,5	19	39	24	29	100	76	116	154	16	47	M8	M6	5,5	14	M5	5	5,5	12	12	25
6011 - 25L	40	4	10,5	12,5	19	39	24	29	100	76	116	154	16	47	M8	M6	5,5	14	M5	5	5,5	12	12	25
6011 - 32R	45	4,5	14,5	16,5	32,5	55	29	34	115	82,5	138	175	21	48	M10	M8	5,5	16	G1/8	4,5	5,5	22,5	10	32
6011 - 32L	45	4,5	14,5	16,5	32,5	55	29	34	115	82,5	138	175	21	48	M10	M8	5,5	16	G1/8	4,5	5,5	22,5	10	32
6011 - 40R	55	5	19,5	24	27,5	55	29	40	115	82,5	137	175	21	48	M10	M8	5,5	16	G1/8	6,5	7	17,5	10	40
6011 - 40L	55	5	19,5	24	27,5	55	29	40	115	82,5	137	175	21	48	M10	M8	5,5	16	G1/8	6,5	7	17,5	10	40
6011 - 50R	64	6	20	23	43	75	37	50	149	105	174	228	20	66	M12	M10	6,5	20	G1/8	6	6,5	33	16	50
6011 - 50L	64	6	20	23	43	75	37	50	149	105	174	228	20	66	M12	M10	6,5	20	G1/8	6	6,5	33	16	50

**Not: Döner Tip Bağlantı Elemanları, sadece "Y" stroğu sırasında sıkma yapabilir.**  
 Note: Swing clamps can squeezing only during the "Y" stroke.