

6010-1

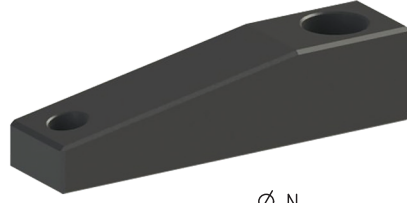

Sıkma Kolu Squeezing Arm

Montaj seçenekleri Mounting options.

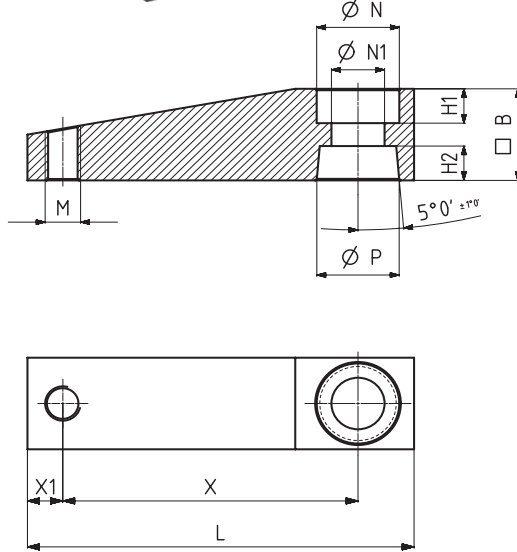
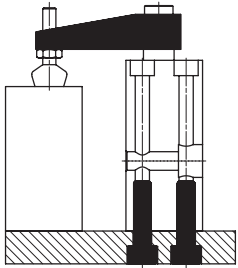

NOT:

- Çelik malzemeden üretilmiş ve korozyon direnci için fosfat kaplama yapılmıştır.

Aksesuarlar : (fiyata dahil değildir)

1-) Baskı ucu (911, 912, 913, 914, 915, 916)

Sıkma kolunun montajı :

- 1-) Sıkma kolunu yaylı rondela ve civata ile piston mili üzerine tutturun.
- 2-) Sıkma kolunu çevirerek pozisyonunu ayarlayın.
- 3-) Anahtar ile sıkma kolunu tutup, civatayı sabitleyin.

Sıkma kolunun sökülmesi :

- 1-) Anahtar ile sıkma kolunu tutarak civatayı çözün.
- 2-) Aşağıdaki resimde görüldüğü şekilde, plastik çekiç ile alttan yukarı doğru hafifçe vurarak sıkma kolunu piston milinden ayırın.

Dikkat: Aşağıdaki resimde olduğu gibi, kesinlikle yandan darbe uygulanmamalıdır.

NOTE:

- Made of steel and phosphate coated for corrosion resistance.

Accessories : (not included in the price)

1-) Squeeze part(911,912,913,914,915,916)

Mounting of squeezing arm:

- 1-) Set up squeezing arm with spring washer and bolt on the piston rod.
- 2-) Turn squeezing arm into position.
- 3-) Hold clamping arm fixed with wrench and tighten bolt.

Squeezing arm removal:

- 1-) Hold clamping arm fixed with wrench and loosen bolt.
- 2-) As in the following picture, With light blows from below (plastic hammer), separate squeezing arm from the piston rod.

Caution!: As in the following picture, Definitely, from side blow should not be applied.

KOD	MODEL NO	B	H1	H2	L	M	ØN	ØN1	ØP	X	X1	AĞIRLIK (WEIGHT) (gr ±%)
6010-1-25	6012-6013-6014-6016-25	16	6	6,5	66	M6	14,7	8,5	14	50	6	90
6010-1-32	6012-6013-6014-6016-32	20	7	9	80	M8	14,7	8,5	16	60	10	183
6010-1-40	6012-6013-6014-6016-40	20	7	9	90	M8	14,7	8,5	16	70	10	213
6010-1-50	6012-6013-6014-6016-50	25	9	10	105	M12	18,5	10,5	20	80	10	370



6010-2

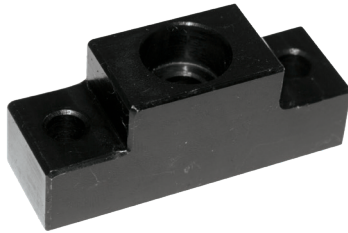

Sıkma Kolu Adaptörü Squeezing Arm Adapter

NOT:

- Çelik malzemeden üretilmiş ve korozyon direnci için fosfat kaplama yapılmıştır.
- Özel yapıdaki sıkma kollarının montajı için kullanılır.

NOTE:

- Made of steel and phosphate coated for corrosion resistance.
- Used for mounting of special construction squeezing arm.

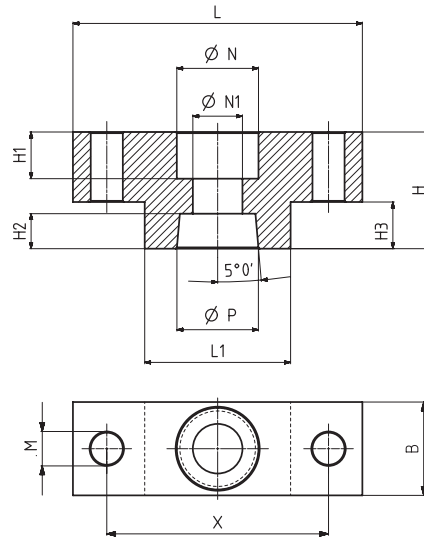

Montaj seçenekleri Mounting options.

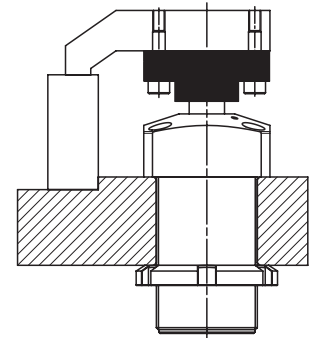

KOD	MODEL NO	B	H	H1	H2	H3	L	L1	M	ØN	ØN1	ØP	X	AĞIRLIK (WEIGHT) (gr ±%)
6010-2-25	6012-6013-6014-6016-25	16	20	8	6,5	8	50	25	5,5	14,5	8,5	14	38	74
6010-2-32-40	6012-6013-6014-6016-32-40	20	25	11	9	10	60	30	7	14,5	8,5	16	45	147
6010-2-50	6012-6013-6014-6016-50	25	30	14	10	12	65	30	9	18,5	10,5	20	48	220

1-) Tek bir sıkıştırma kolu ve piston mili arasında bağlantı elemanı olarak montaj.

1-) Mounting as a connection element between an individual squeezing arm and the piston rod.