

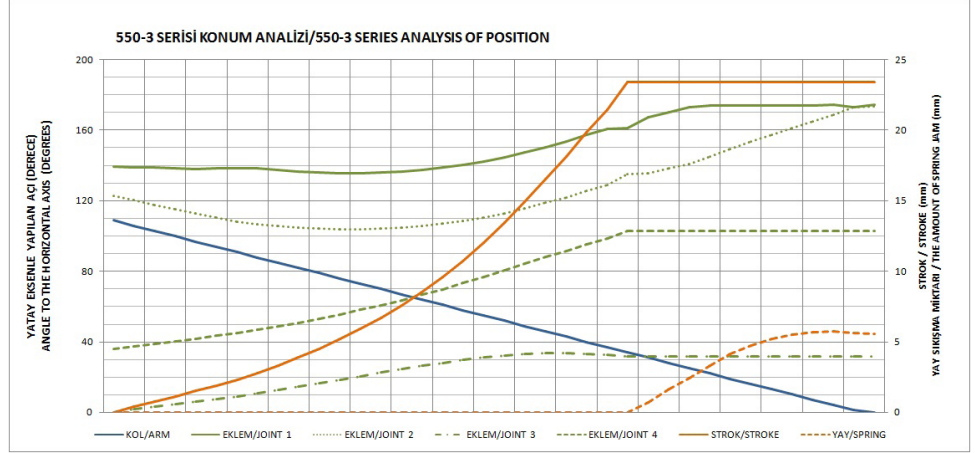

MODEL NO	F1 (N)	F3 (N)	Fi	STROK	AĞIRLIK (WEIGHT) (gr ±%)
			VERİM (YIELD) (F1:Fi)		
551 - 3	2500	3200	14:1	23	530

F1 : BASKI KUVVETİ (EXERTING FORCE), F3 : TUTMA KAPASİTESİ (HOLDING CAPACITY)
Fi : UYGULAMA KUVVETİ (APPLIED FORCE)



Ürün özellikleri ;

Otomatik mesafe ayarı sayesinde 16 mm kalınlığa kadar olan iş parçalarını baskı kuvveti değişmeden sıkıştırabilir.

Sıkma kuvveti mekanizma üzerinde bulunan ayar vidasından ayarlanabilir.

Product features:

The automatic distance adjustment property of this toggle clamp enables clamping of work pieces of up to 16 mm without any variation in the exerted force. The clamping force can be adjusted to your particular needs by turning the setscrew on the mechanism.

Ayak Tipi: Yatay, Alçak Tabanlı

Body Mounting Base: Horizontal, Low Base



552
Sayfa/Page: 67



511
Sayfa/Page: 54

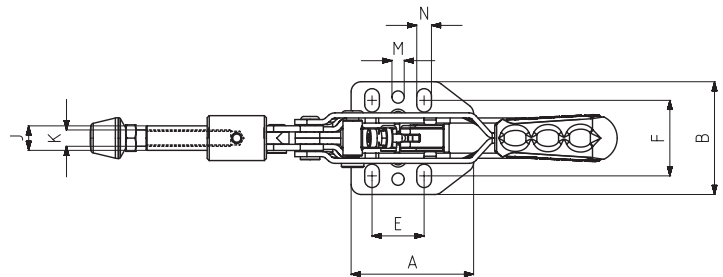
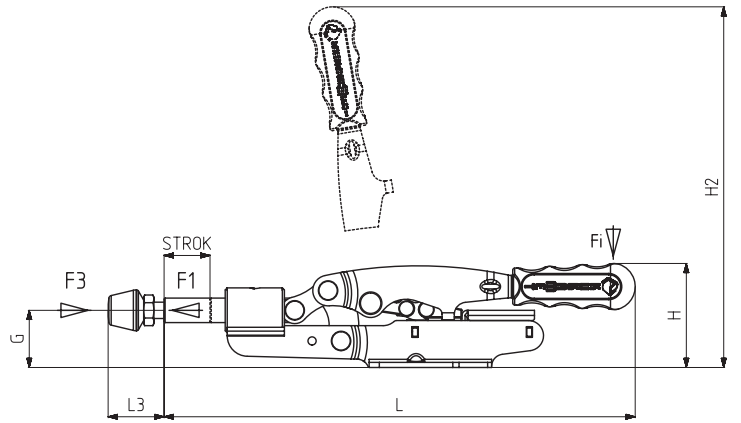
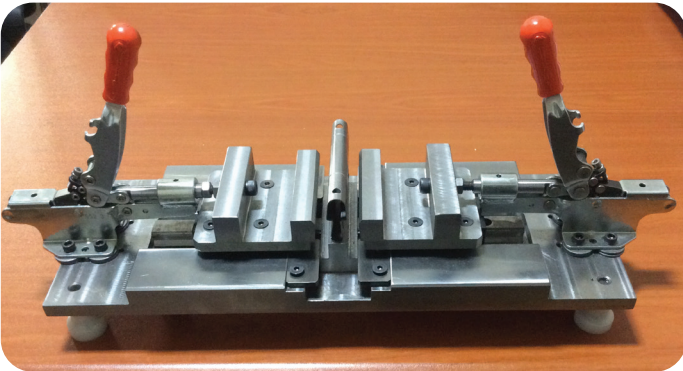

MODEL NO	A	B	E	F	G	H	H2	J	K	L	L3 Min	L3 Max	M	N
551 - 3	60	55.5	25.5	37	28	51	187	12	M8	231	24	58	Ø6	7x11,5